



TweeMid TM 4055-8

Tweeter - Mid,

Mid Ø 2", Ø 1" voicecoil, 8Ω / Tweeter Ø 1.125", Ø 1" voicecoil, 8Ω

SPECIFICATIONS

General Data

		Mid	Tweeter
Overall Dimensions	DxH	143.20 mm x 80 mm	
Nominal Power Handling (DIN)	P	200w	120w
Transient Power 10ms		1000w	1000w
Sensitivity 2.83V/1M		86.5 dB	86.5 dB SPL
Frequency Response		See graph	see graph
Cone Material		Acuflex™ hand coated soft dome	
Net Weight	Kg	0.48	

Electrical Data

		Mid	Tweeter
Nominal Impedance	Z	8Ω	8Ω
DC Resistance	Re	6.50Ω	5.42Ω
Voice Coil Inductance @ 10KHz	LBM	0.17 mH	0.07 mH

Voice Coil and Magnet

		Mid	Tweeter
Voice Coil Diameter	DIA	54 mm (2.126")	28 mm (1.125")
Voice Coil Height		6 mm (0.236")	2.7 mm (0.106")
HE Magnetic Gap Height	HE	4 mm (0.157)	2.5 mm (0.098")
Max. Linear Excursion	X	±1 mm	
Voice Coil Former		Aluminum	
Voice Coil Wire		Hexatech™ Aluminum	
Number Of Layers		2	
Magnet System Type		Hybrid rear vented	Neodmium Vented
B Flux Density	B	0.85 T	1.4 T
BL Product	BXL	5.3 N.A	2.0 N.A

T-S Parameters

		Mid	Tweeter
Suspension Compliance	Cms	0.07 mm/N	0.21
Mechanical Q Factor	Qms	0.84	1.28
Electrical Q Factor	Qes	1.32	1.55
Total Q Factor	Qts	0.51	0.70
Mechanical Resistance	Rms	6.85	0.91
Moving Mass	Mms	2.50 g	0.29 g
Eq. Cas Air Load (liters)	VAS	0.08	0.01
Resonant Frequency	Fs	365 Hz	640 Hz
Effective Piston Area	SD	28 cm ²	7 cm ²

FEATURES

- * Seamless Mid and Tweeter combination
- * 2.1" Acuflex™ hand coated soft dome
- * 2.1" Large Hexatech™ Aluminum voice coil
- * Internally damped, Aluminum rear chamber
- * Wide range linear performance
- * High power handling

Unit Dimensions

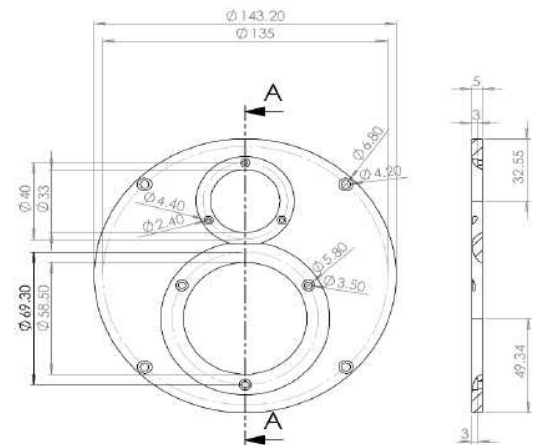

Total Depth 80mm

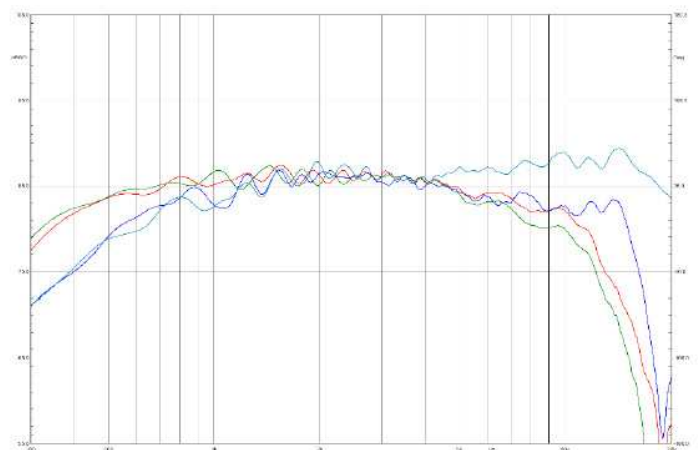
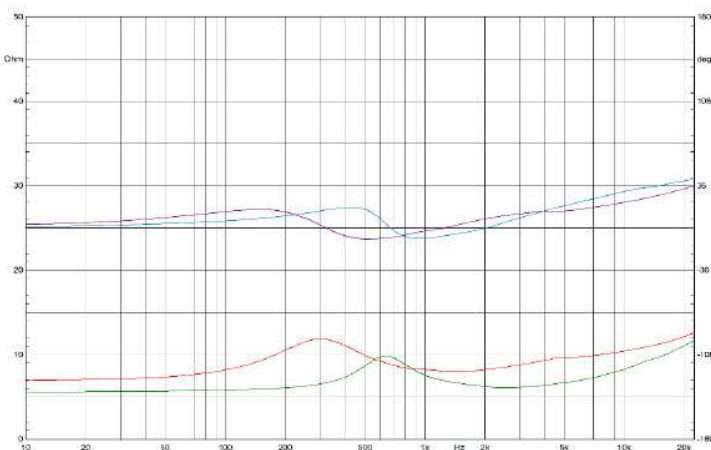

Measured on IEC baffle using Bruel & Kjaer 3144 model microphone.

Morel operate policy of continuous product design improvement, consequently specifications are subject to alteration without prior notice.